

Korat-1916K5



- 19" LCD Monitor with LED Backlight
- Dual telescopic rail
- 16 Port CAT.5 KVM



Korat-1916K5 is a 19" Monitor-KeyBoard-Drawer with LED Backlight. A value keyboard with number block and touchpad and the integrated 16 Port CAT.5 KVM-switch are completing the external design. The casing conforms the 1U Standard, is easily installed and mountable with the included mounting kit. The integrated telescopic dual-rail ensures the separate pull out of keyboard and monitor and makes the device to a perfect combination of workstation and monitoring center. A device for professionals.

Specifications

- Tree-chainable for next level up to 16 KVM-0116PMC switches
- Tree-chaining distance up to 5 meters
- Port capacity is scalable up to 256 PCs by tree-chaining with PMC models
- Computer-Selection by Keyboard-Hotkeys and OSD-Menu
- On-Screen-Display and system notifications as a Pop-Up
- Additional console port (competing)
- With an additional (optional) Receiver PMC-300R and by an 1:1 Cat.x cable connection the control panel can be reflected.
- Supports all USB suitable operating systems: for example DOS, Windows Series / Server 2008 / Server 2013, Linux, MacOS, etc.
- Numeric LED-Status displays for a clear display of the port status
- Buzzer sound confirms the hotkey and port circuit (de-activated)
- AutoScan dwell time of 5 ~ 95 seconds for OSD programmable
- Password protection
- Auto-Logout ,Timeout-Support
- Firmware / Software upgradeable

Properties

- 1U 19" LCD console, 607mm depth
- Stepless, adjustable angle from 0 to 105° over high quality unique connecting adapter
- Easy one man assembly with the included installation angles
- Integrated 16 Port CAT.5 KVM-switch
- Adjustable depth from 560mm up to 900mm tread depth
- full metal handle
- Practical knurles screws
- High graphic resolution, up to 1280 x 1024 with 60Hz DDC, DDC2 and DDC2B

Keyboard versions:

Available in following versions: German (DE), US-English (US), French (FR), Spanish (SP), Italian (IT). Swiss / German (CH) and swedish / finnish (SWE/FI)

Versions available on request: UK-English (UK), Turkish (TK), Russian(RU) and Arabian (AR)

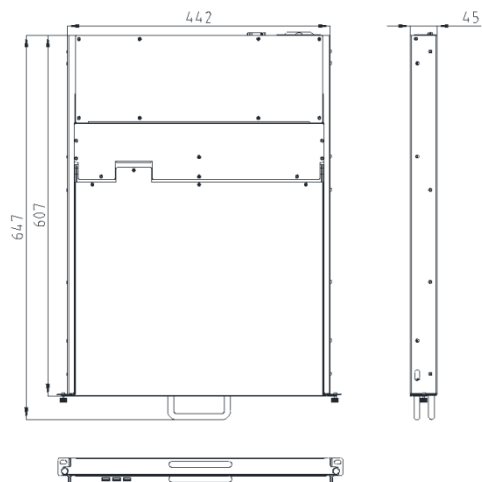

Technical data:

Connections KVM	Graphic / Keyboard / Mouse	16 x RJ-45
	Console(remote)	1 x RJ-45 for PMC-300R
	Console (local)	1 x VGA/2 x USB-A
	Firmware	1 x USB-B
	Power supply	1 x DC-12V
	Remote	1 x RJ-45
Connection cable / Dongle (not included in the delivery)	VGA & 2 x PS/2	Dongle-PS/2 V3
	VGA & 1 x USB	Dongle-USB V3
Switch	LCD settings	5 Pressure switch
	ON / OFF	1 Pressure switch
	OFF (LCD pushed back)	1 covert pressure switch
LED-Display panel	Operation	1 x green/red
	Number	1 x blue
	Capital letters	1 x blue
	Scroll	1 x blue
LED-Display KVM	Port/Switch	16 green (Port)
Emulation	Keyboard/ Mouse	USB & PS/2
Port selection	Push buttons / hotkey / OSD	
Graphic	19" LCD	1280 x 1024
	Colors	16,2 Mio.
	Frame Rate	H: 31,0 KHz. – 81,0 KHz. V: 56,0 KHz. – 76,0 KHz.
	Viewing angle	H: 140° / V: 130°
	Bandwith	140 Mhz.
	Brightness	300 cd/m ²
	Contrast	1000 : 1
	Reaktion time	4 ms.
	Pixel pitch	0,294mm (H) x 0,294mm (V)
Backlight	LED	
Input values	100 V. – 240 V. AC, 48 Hz – 62 Hz	
Output values	DC 12V., 4,16A	
Power consumption	230 V / 19,5 Watt / Standby: 11,9 Watt	
Certification	RoHS, RoHS2, CE	
Environment	Operating temperature	-10 – 50°C
	Storage temperature	-20 – 60°C
	Humidity	0 – 80% relative humidity (non condensing)
Physical properties	Casing	High performance steel
	Color	RAL 9005
	Weight	17,4 kg incl. angles
	Dimension (L x W x H) without handle	60,70 x 44,20 x 4,5 cm (19" / 1U)
	Dimension (L x W x H) with handle	64,70 x 44,20 x 4,5 cm (19" / 1U)
Packaging	Weight	19,20 kg
	Dimension (L x W x H)	79 x 59 x 22 cm